



# MQHE-28E-P Passive Filter

## HIGH RELIABILITY EMI FILTER

<b>-70V to +70V</b> Continuous Input	<b>10A</b> Output Current	<b>60mΩ @ 125°C</b> Max. DC Resistance	<b>&gt;80dB @ 500kHz</b> Differential Attenuation
---	------------------------------	---	--

**FULL POWER OPERATION: -55°C to +125°C**

The MilQor® series of high-reliability EMI filters brings SynQor's field proven technology and manufacturing expertise to the Military/Aerospace industry. SynQor's innovative QorSeal® packaging approach ensures survivability in the most hostile environments. Compatible with the industry standard format, these filters have high differential-mode and common-mode attenuation, low DC resistance, and a stabilizing bulk capacitor resistor. They follow conservative component derating guidelines and they are designed and manufactured to comply with a wide range of military standards.

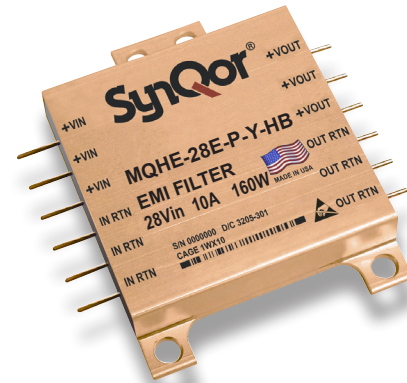

DESIGNED & MANUFACTURED IN THE USA  
FEATURING QORSEAL® HI-REL ASSEMBLY

### Design Process

MQHE series filters are:

- Designed for reliability per NAVSO-P3641-A guidelines
- Designed with components derated per:
  - MIL-HDBK-1547A
  - NAVSO P-3641A

### Qualification Process

MQHE series filters are qualified to:

- MIL-STD-810F
  - consistent with RTCA/DO-160E
- SynQor's First Article Qualification
  - consistent with MIL-STD-883F
- SynQor's Long-Term Storage Survivability Qualification
- SynQor's on-going life test

### In-Line Manufacturing Process

- AS9100 and ISO 9001 certified facility
- Full component traceability
- Temperature cycling
- Constant acceleration
- 24, 96, 160 hour burn-in
- Three level temperature screening

### Features

- 10 amps output current
- Very low DC resistance
- > 80 dB differential-mode attenuation at 500kHz
- > 60 dB common-mode attenuation at 500kHz
- Stabilizing bulk capacitor and damping resistor included
- All capacitors are X7R multi-layer ceramic
- Designed to meet all MIL-STD 461 EMI and most RTCA/DO-160E Section 22 lightning requirements

### Specification Compliance

MQHE series filters (with MQHL converters) are designed to meet:

- MIL-HDBK-704-8 (A through F)
- RTCA/DO-160E Section 16
- MIL-STD-1275D for Vin > 16V
- DEF-STAN 61-5 (part 6)/5 for Vin > 16V
- MIL-STD-461 (C, D, E, F)
- RTCA/DO-160E Section 22



**MQHE-28E-P**  
**Current: 10A**

**Technical Specification**

**BLOCK DIAGRAM**

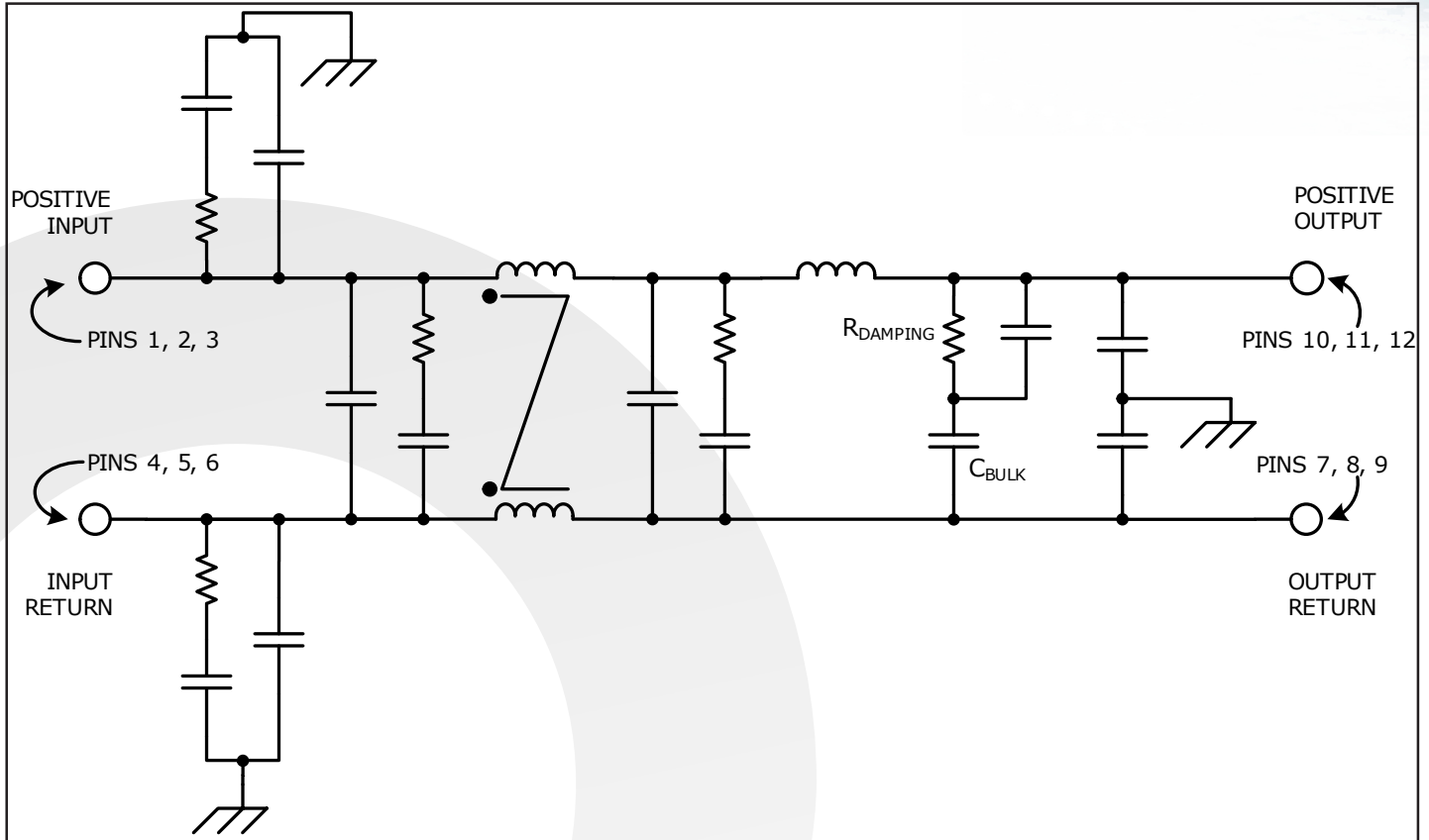

**TYPICAL CONNECTION DIAGRAM**

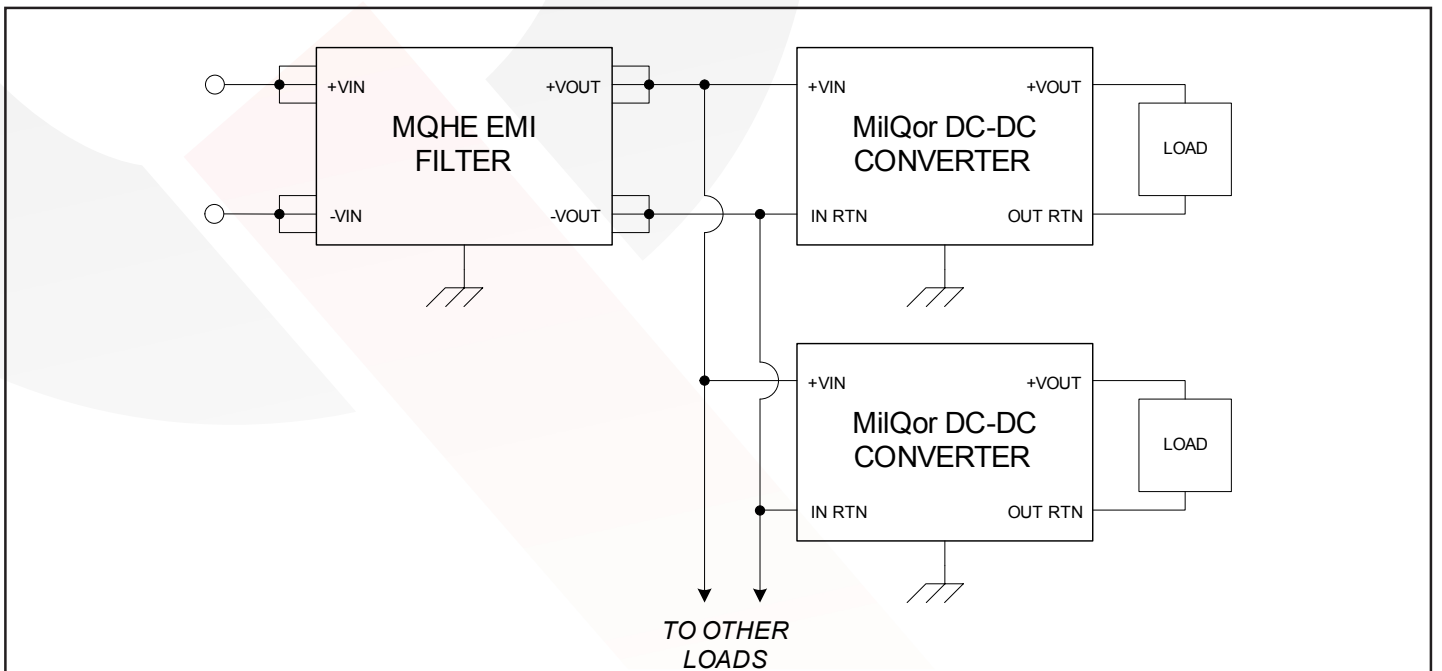



**MQHE-28E-P**  
**Current: 10A**

**Technical Specification**

**MQHE-28E-P ELECTRICAL CHARACTERISTICS**

Parameter	Min.	Typ.	Max.	Units	Notes & Conditions	Group A Subgroup (See Note 3)
Specifications subject to change without notice						
<b>ABSOLUTE MAXIMUM RATINGS</b>						
Input Voltage					See Note 1	
Continuous	-100		100	V		
Transient ( $\leq 1$ s)	-200		200	V		
Isolation Voltage (Input/Output to case)						
Continuous	-500		500	V		
Transient ( $\leq 1$ s)	-1000		1000	V		
Output Current			10	A		
Operating Case Temperature	-55		125	$^{\circ}$ C	HB Grade Products, See Note 4	
Storage Case Temperature	-65		135	$^{\circ}$ C		
Lead Temperature (20 s)			300	$^{\circ}$ C		
<b>ELECTRICAL CHARACTERISTICS</b>						
Input Voltage					See Note 1	
Continuous	-70		70	V		1, 2, 3
Transient ( $\leq 1$ s, $R_s^* = 0 \Omega$ )	-80		80	V		
Transient ( $\leq 100$ ms, $R_s^* = 0 \Omega$ )	-100		100	V		
Output Voltage (continuous)	$V_{out} = V_{in} - (I_{in} \times R_{dc})$			V		1, 2, 3
Output Current (continuous)			10	A		1, 2, 3
DC Resistance RDC						
TCASE = 25 $^{\circ}$ C			40	m $\Omega$		1
TCASE = 125 $^{\circ}$ C			60	m $\Omega$		3
Power Dissipation (10A output current)						
TCASE = 25 $^{\circ}$ C			4	W		
TCASE = 125 $^{\circ}$ C			6	W		1, 2, 3
Total Differential-Mode Capacitance		54		$\mu$ F	Measured across input or output pins	
Total Common-Mode Capacitance		0.29		$\mu$ F	Measured between any pin to case	
Bulk Capacitor		41		$\mu$ F		
Damping Resistor		0.3		$\Omega$		
Noise Attenuation					See Figure 1	
<b>INPUT VOLTAGE SPIKE SUPPRESSION</b>						
Output Voltage Deviation due to a Spike					See Note 2	
Input Voltage Spike (Centered on $V_{in}$ )						
$\pm 250$ V, 100 $\mu$ s, $E_{max} = 15$ mJ	-5		5	$\Delta$ V	MIL-STD-1275B/D	
$\pm 600$ V, 10 $\mu$ s, $R_s^* = 50 \Omega$	-5		10	$\Delta$ V	RTCA/DO-160E	
<b>ISOLATION CHARACTERISTICS</b>						
Isolation Voltage (any pin to case)						
Continuous	-500		500	V		1
Transient ( $\leq 100 \mu$ s)	-800		800	V		
Isolation Resistance (any pin to case)	100			M $\Omega$		1

\*  $R_s$  = Source Impedance



# Technical Specification

**MQHE-28E-P**  
**Current: 10A**

## MQHE-28E-P ELECTRICAL CHARACTERISTICS (Continued)

Parameter	Min.	Typ.	Max.	Units	Notes & Conditions	Group A Subgroup (See Note 3)
Specifications subject to change without notice					Vin=28V DC ±5%, Iout= 10A unless otherwise specified	
<b>RELIABILITY CHARACTERISTICS</b>						
Calculated MTBF (MIL-STD-217F2)						
GB @ Tcase = 70°C		231		10 <sup>6</sup> Hrs.		
AIF @ Tcase = 70°C		17.7		10 <sup>6</sup> Hrs.		
<b>WEIGHT CHARACTERISTICS</b>						
Device Weight		45		g		

### Electrical Characteristics Notes

1. While the filter will survive these input voltage limits, the filter's output voltage will be outside the limits for an MQHL converter input voltage range.
2. Verified by qualification testing and analysis.
3. Only the ES and HB grade products are tested at three temperatures. The C grade products are tested at one temperature. Please refer to the Construction and Environmental Stress Screening Options table for details.
4. The specified operating case temperature for ES grade products is -45°C to 100°C. The specified operating case temperature for C grade products is 0°C to 70°C.

\* R<sub>S</sub> = Source Impedance



**MQHE-28E-P**  
**Current: 10A**

**Technical Specification**

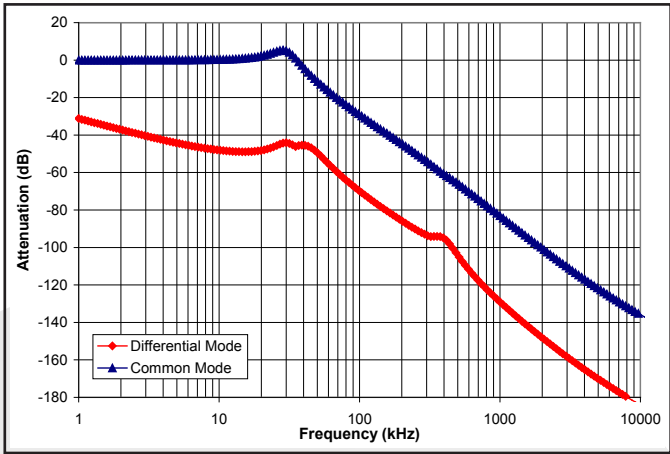

**Figure 1:** Simulation of calculated common-mode and differential-mode current attenuation. The curves plot the ratio of noise current in a 50Ω LISN sensing port connected to the noise output side of the filter to the noise current on the input side. The filter case is also connected to chassis ground. Refer to Figures A and B.

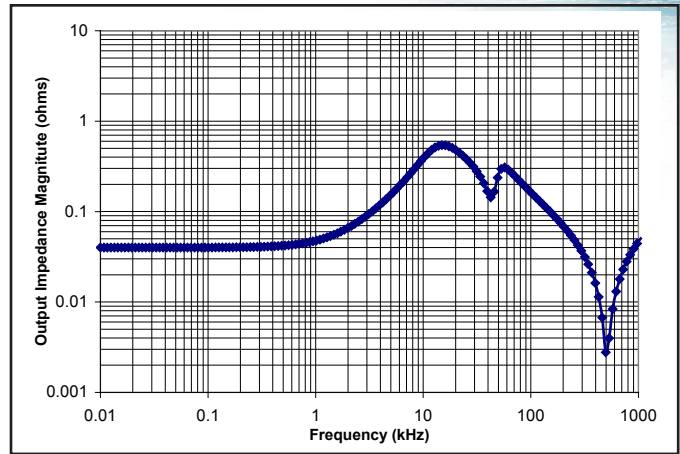

**Figure 2:** Typical Output Impedance (magnitude) of the filter looking back into its output pins with the input pins connected to a source with zero source impedance.

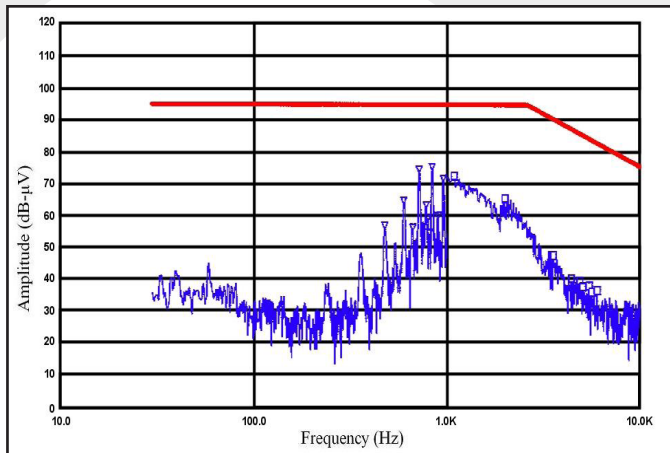

**Figure 3:** MIL-STD-461E Method CE101 Low Frequency Conducted Emissions of the MQHE-28-P filter with a MQHL-28-05S at 50W output. Limit line (in red) is the 'Submarine Applications DC Curve'.

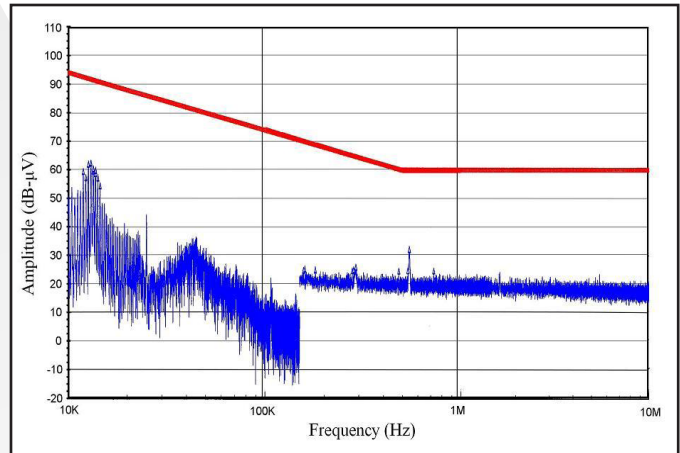

**Figure 4:** MIL-STD-461E Method CE102 High Frequency Conducted Emissions of the MQHE-28-P filter with a MQHL-28-05S at 50W output. Limit line (in red) is the 'Basic Curve'.

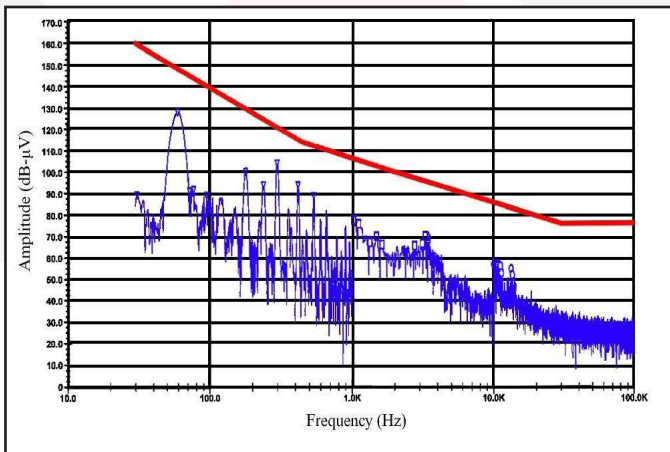

**Figure 5:** MIL-STD-461E Method RE101 Low Frequency Radiated Emissions of the MQHE-28-P filter with a MQHL-28-05S at 50W output. Limit line (in red) is the 'Standard Curve' from MIL-STD-461C Method RE01, which is more strict than all RE101 limits.

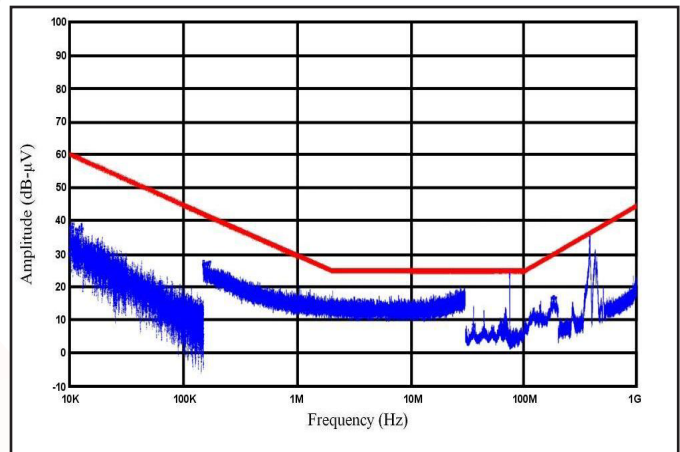

**Figure 6:** MIL-STD-461E Method RE102 High Frequency Radiated Emissions of the MQHE-28-P filter with a MQHL-28-05S at 50W output. Limit line (in red) is the 'Submarine External to Pressure Hull Curve'.



## BASIC OPERATION AND FEATURES

The MQHE is a multi-stage differential-mode and common-mode passive EMI filter designed to interface a power source with one or more SynQor DC/DC converters (or other loads that create EMI). Each stage of this filter is well damped to avoid resonances and oscillations, and only X7R multi-layer ceramic capacitors are used. Figure 1 shows the typical differential and common-mode attenuation provided by this filter when the source impedance is  $50\Omega$  to chassis ground on each input line.

The MQHE EMI filter includes a large bulk capacitor (also X7R) with a series damping resistor to correct for the unstabilizing effect of a converter's negative input resistance. A white paper discussing this negative input resistance and the need for corrective damping can be found on the SynQor website (see Input System Instability application note). Figure 2 shows the magnitude of the filter's output impedance when the filter input is connected to a stiff voltage source.

The input voltage surge and spike compliance matrix displays the worst case requirements listed in various 28V Military (Vehicle and Aircraft) and Civil Aircraft standards. The MQHE EMI filter is designed to handle all of the short duration voltage spike requirements of these standards (with certain assumptions regarding DEF-STAN 61-5). Some of the long duration voltage surge requirements remain within the 50V maximum transient rating of a SynQor MQHL-28 DC/DC converter.

When used with SynQor's DC/DC converters, the MQHE EMI filter is designed to pass all of the relevant MIL-STD-461C/D/E/F requirements to their most stringent limits. The MIL-STD-461 Compliance Matrix Table lists these requirements and describes the setup used to pass them. Figures 3 - 6 show results from selected conductive and radiated emissions tests.

The filter is also designed to pass the waveform types and applications specified in RTCA/DO-160E Section 22 (Lightning Induced Transient Susceptibility) to Level 4. The Section 22 Compliance Matrix Table lists these waveforms and applications and describes the setup used to pass them.

A typical application would place the MilQor filter close to the input of the DC/DC converter, with the cases of the filter and the converter connected together through a ground plane. Both cases are electrically conductive, so connection to the cases can be made with the fasteners used to secure the device.

Do not connect the outputs of multiple MQHE filters in parallel. Connecting filters in this manner may result in slightly unequal currents to flow in the positive and return paths of each filter. These unequal currents may cause the internal common-mode chokes to saturate and thus cause degraded common-mode rejection performance.

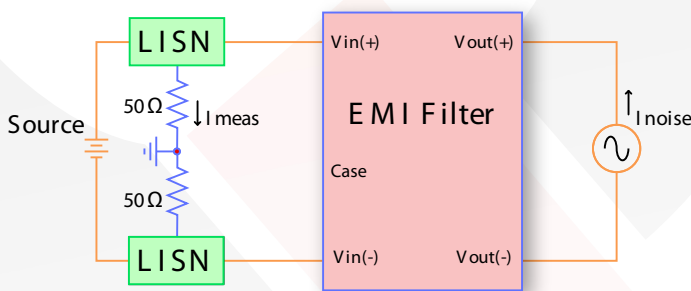

Figure A: Differential-Mode Current Attenuation,  $I_{meas} / I_{noise}$

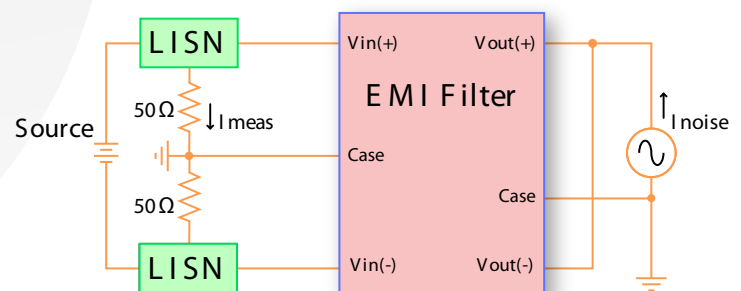

Figure B: Common-Mode Current Attenuation,  $I_{meas} / I_{noise}$



# Technical Specification

## MIL-STD-461 COMPLIANCE MATRIX

This table shows the MIL-STD-461 requirements/limits that have been met\* by a stand-alone setup comprised of:

- MQHE-28-P Filter
- MQHL-28-05S DC/DC Converter
- Resistive Load
- Metal Chassis Plane

	-461C		-461D/E/F	
	Requirement	Most Stringent Limit Listed	Requirement	Most Stringent Limit Listed
Conducted Emissions	CE01 CE03 CE07	Class A5 (Submarine) Class A5 (Submarine) Class A1 (Aircraft)	CE101 CE102	Submarine Basic Curve
Conducted Susceptibility	CS01 CS02	Class A5 (Submarine) Class A5 (Submarine)	CS101	Curve #2
	CS06	Class A1/A5 (Aircraft/Sub)	CS106	(461F Only)
	CS10 CS11	Class A5 (Submarine) Class A5 (Submarine)	CS114 CS115 CS116	Curve #5 Basic Waveform I <sub>MAX</sub> = 10A
Radiated Emissions	RE01 RE02†	Class A5 (Submarine) Class A5 (Submarine)	RE101 RE102†	Navy Submarine
Radiated Susceptibility	RS01 RS02 RS03	Class A5 (Submarine) Class A1/A5 (Aircraft/Sub) Class A4 (Surface Ship)	RS101 RS103	Army Aircraft External

Met by any MQME/MQHE Filter	Met by an MQME Filter having the Transient Suppression and Reverse Polarity Protection Features
-----------------------------	---

\* Susceptibility requirements/limits are deemed to have been met as long as transient deviations in the converter's output voltage remain within ±10% of its initial value.

† Met with metal screen shield covering the filter, converter, and resistive load.



**MQHE-28E-P**  
**Current: 10A**

**Technical Specification**

**RTCA/DO-160E SECTION 22 COMPLIANCE MATRIX  
(LIGHTNING INDUCED TRANSIENT SUSCEPTIBILITY)**

The following table shows the RTCA/DO-160 Section 22 requirements that have been met\* by a stand-alone setup comprised of:

- MQME-28-P (or -T) Filter
- MQFL-28-05S DC/DC Converter
- Resistive Load
- Metal Chassis Plane
- Unshielded Power Cable Bundle

	Waveform	Maximum Level Passed	Test Conditions
Pin Injection	3	4	Signal applied to +Vin pin. Input Return pin connected to system ground
	4	4†	
	5a	4†	
Single- and Multiple-Stroke Cable Induction	2	4**	Signal applied to unshielded power cable bundle
	3	4	
Single- and Multiple-Stroke Ground Injection	4	4	Signal applied between metal ground plane and system ground
	5a	4	
Multiple-Burst Cable Induction	3	4	Signal applied to unshielded power cable bundle

Met by any MQME/MQHE Filter	Met by an MQME Filter having the Transient Suppression and Reverse Polarity Protection Features
-----------------------------	---

\* Requirement is deemed to have been met as long as transient deviations in the converter’s output voltage remain within ±10% of its initial value.

† For these waveforms at Level 3 and above, an external transient suppressor of sufficient energy rating must be placed across the filter’s input pins to keep the differential transient input voltage below +200V/-50V. Negative polarity waveforms may cause power flow to the converter to be interrupted long enough to cause a graceful shutdown and restart of the converter. Also, the reverse voltage protection feature of the -T filter is required to protect the converter (but not the filter) from negative polarity waveform.

\*\* For this waveform at a Level 4 and above, external transient suppressors of sufficient energy rating must be added between the filter’s input power pins and its case to keep the common-mode transient input voltage below ±800V.



### Technical Specification

## VOLTAGE SURGE AND SPIKE COMPLIANCE MATRIX

These tables show the Voltage Surge and Spike requirements/limits that have been met\* by a stand-alone setup comprised of:

- MQME-28-P (or -T) Filter
- MQFL-28-05S DC/DC Converter
- 120W Resistive Load
- Metal Chassis Plane

Vehicle 28Vin	Part	Worst Case Over-Voltage Surge (Voltage/Duration)	Short Duration Spikes (Voltage/Duration/Impedance)
MIL-STD-1275D	(Gen. + Bat.)	40V / 50ms	±250V / 15mJ / 0.5Ω
	(Bat. only)	100V / 50ms	
	(Gen. only)	100V / 50ms	
DEF STAN 61-5 (PART 6)/5†	(Gen. + Bat.)	40V / 50ms	+130V to -100V max § +90V to -60V / 10µs §
	(Bat. Only)	+70V to -40V / 5ms §	
	(Bat. Only, Non-Regen. Ld. Sw.)	+70V to -40V / 5ms §	
	(Bat. Only, Regen. Ld. Sw.)	80V / 80ms §	
	(Gen. only)	40V / 50ms	+280V to -220V max § +130V to -70V / 10µs §
DEF STAN 61-5 (PART 6)/6†	DIT08.B, DIT07.B	80V / 80ms § 100V / 50ms +110V to -50V / 5ms §	±200V / 200ns / 50Ω
	DET03.A	+174V / 350ms	+90V to -60V / 10µs §
	DET04.A	40V / 50ms §	
	DIT04.A	+70V to -40V / 1ms § +110V / 300ms §	
Aircraft 28Vin	Part	Worst Case Over-Voltage Surge (Voltage/Duration)	Short Duration Spikes (Voltage/Duration/Impedance)
MIL-HDBK-704-8	(704A)	80V / 50ms	N/A
		60V / 550ms	
	(704B, C, D, E, F)	50V / 50ms	
RTCA/DO-160E	(Cat A)	47V / 100ms	±600V / 10µs / 50Ω
		38V / 1s	
	(Cat B)	60V / 100ms	±200V / 10µs / 50Ω
		40V / 1s	
	(Cat C)	80V / 100ms	N/A
		48V / 1s	

Met by any Hi-Rel Filter

Met by an MQME-28-T Filter having the Transient Suppression and Reverse Polarity Protection Features

Met by MQME-28E-T6 Filter Only: Performance Criteria C

\* Surge/spike requirements/limits are deemed to have been met as long as transient deviations in the converter's output voltage remain within ±10% of its initial value.

§ These are defined as the maximum disturbances that equipment can inflict upon the power system, not as disturbances imposed upon utilization equipment. To ensure compatibility, however, these are within the designed stress envelope of the indicated filters & converters.

† For the DEF STAN 61-5 specification:

- 1) Negative surges require reverse voltage protection circuitry to protect the converter (but not the filter) from a negative input. This circuitry is included in the MQME-28-T but not the MQME-28-P and MQHE-28-P filters.
- 2) The negative surges may cause the converter to shut down unless additional holdup capacitance is included.
- 3) Maximum spike voltages are assumed to last <1µs



**MQHE-28E-P**  
**Current: 10A**

**CONSTRUCTION AND ENVIRONMENTAL STRESS SCREENING OPTIONS**

Screening	Consistent with MIL-STD-883F	C-Grade (specified from 0 °C to +70 °C)	ES-Grade (specified from -45 °C to +100 °C)	HB-Grade (specified from -55 °C to +125 °C)
Element Evaluation		No	Yes	Yes
Internal Visual	IPC-A-610 Class 3	Yes	Yes	Yes
Temperature Cycle	Method 1010	No	Condition B (-55 °C to +125 °C)	Condition C (-65 °C to +150 °C)
Constant Acceleration	Method 2001 (Y1 Direction)	No	500 g	Condition A (5000 g)
Burn-in	Method 1015	24 Hrs @ +125 °C	96 Hrs @ +125 °C	160 Hrs @ +125 °C
Final Electrical Test	Method 5005 (Group A)	+25 °C	-45, +25, +100 °C	-55, +25, +125 °C
Mechanical Seal, Thermal, and Coating Process			Full QorSeal	Full QorSeal
External Visual	Method 2009	Yes	Yes	Yes
Construction Process			QorSeal	QorSeal

MilQor® Hi-Rel converters and filters are offered in three variations of environmental stress screening options. All ES-Grade and HB-Grade MilQor Hi-Rel converters use SynQor’s proprietary QorSeal® Hi-Rel assembly process that includes a Parylene-C coating of the circuit, a high performance thermal compound filler, and a nickel barrier gold plated aluminum case. Each successively higher grade has more stringent mechanical and electrical testing, as well as a longer burn-in cycle. The ES- and HB-Grades are also constructed of components that have been procured through an element evaluation process that pre-qualifies each new batch of devices.



# SynQor®

## Technical Specification

**MQHE-28E-P**  
**Current: 10A**

### MIL-STD-810F Qualification Testing

MIL-STD-810F Test	Method	Description
Fungus	508.5	Table 508.5-I
Altitude	500.4 - Procedure I	Storage: 70,000 ft / 2 hr duration
	500.4 - Procedure II	Operating: 70,000 ft / 2 hr duration; Ambient Temperature
Rapid Decompression	500.4 - Procedure III	Storage: 8,000 ft to 40,000 ft
Acceleration	513.5 - Procedure II	Operating: 15 g
Salt Fog	509.4	Storage
High Temperature	501.4 - Procedure I	Storage: 135 °C / 3 hrs
	501.4 - Procedure II	Operating: 100 °C / 3 hrs
Low Temperature	502.4 - Procedure I	Storage: -65 °C / 4 hrs
	502.4 - Procedure II	Operating: -55 °C / 3 hrs
Temperature Shock	503.4 - Procedure I - C	Storage: -65 °C to 135 °C; 12 cycles
Rain	506.4 - Procedure I	Wind Blown Rain
Immersion	512.4 - Procedure I	Non-Operating
Humidity	507.4 - Procedure II	Aggravated cycle @ 95% RH (Figure 507.5-7 aggravated temp - humidity cycle, 15 cycles)
Random Vibration	514.5 - Procedure I	10 - 2000 Hz, PSD level of 1.5 g <sup>2</sup> /Hz (54.6 g <sub>rms</sub> ), duration = 1 hr/axis
Shock	516.5 - Procedure I	20 g peak, 11 ms, Functional Shock (Operating no load) (saw tooth)
	516.5 - Procedure VI	Bench Handling Shock
Sinusoidal vibration	514.5 - Category 14	Rotary wing aircraft - helicopter, 4 hrs/axis, 20 g (sine sweep from 10 - 500 Hz)
Sand and Dust	510.4 - Procedure I	Blowing Dust
	510.4 - Procedure II	Blowing Sand



**MQHE-28E-P**  
**Current: 10A**

**Technical Specification**

**First Article Testing consistent with MIL-STD-883F**

MIL-STD-883F Test	Method	Description
Electrical Tests	5005	
Physical Dimensions test	2016	
Resistance to Solvents test	2015.13	
Solderability test	2003.8	
Lead Integrity test	2004.5	
Salt Atmosphere test	1009.8	Condition "A"
Adhesion of Lead Finish test	2025.4	
Altitude Operation test	1001	Condition "C"
ESD Sensitivity	3015.7	Class 2
Stabilization Bake test	1008.2	Condition "C"
Vibration Fatigue test	2005.2	Condition "A"
Random Vibration test	2026	Condition "II K"
<b>Sequential Test Group #1</b>		
Life Test – Steady State test	1005.8	
Life Test – Intermittent Duty test	1006	
<b>Sequential Test Group #2</b>		
Temperature Cycle test	1010.8	Condition "C"
Constant Acceleration test	2001.2	Condition "A"
<b>Sequential Test Group #3</b>		
Thermal Shock test	1011.9	Condition "B"
Temperature Cycle test	1010.8	Condition "C"
Moisture Resistance test	1004.7	With Sub cycle
<b>Sequential Test Group #4</b>		
Mechanical Shock test	2002.4	Condition "B"
Variable Frequency Vibration test	2007.3	Condition "A"



**MQHE-28E-P**  
**Current: 10A**

**Technical Specification**

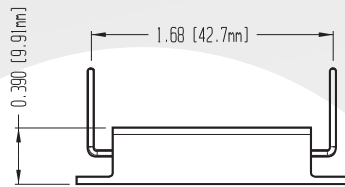
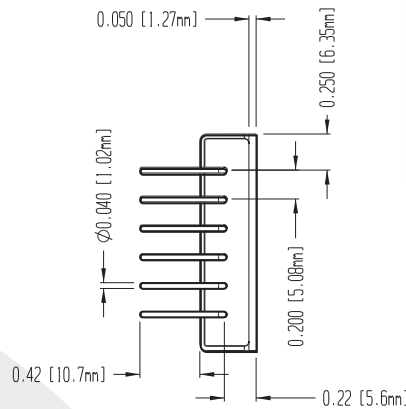
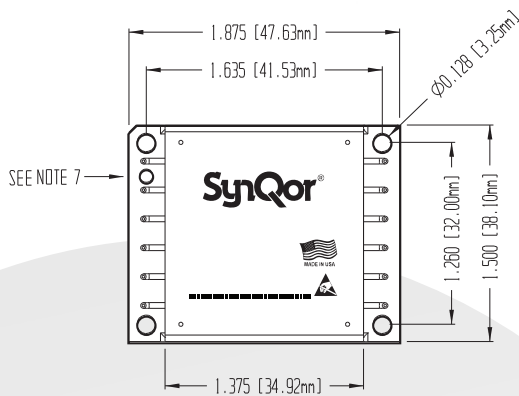

**Case U**

**PIN DESIGNATIONS**

Pin #	Function
1	Positive input
2	Positive input
3	Positive input
4	Input return
5	Input return
6	Input return
7	Output return
8	Output return
9	Output return
10	Positive output
11	Positive output
12	Positive output

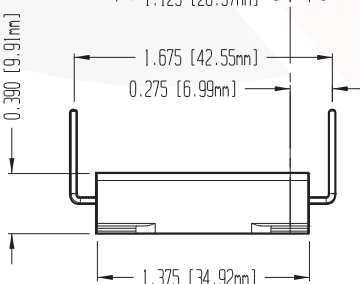
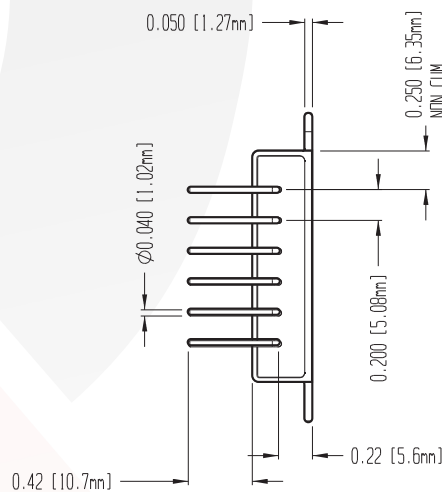
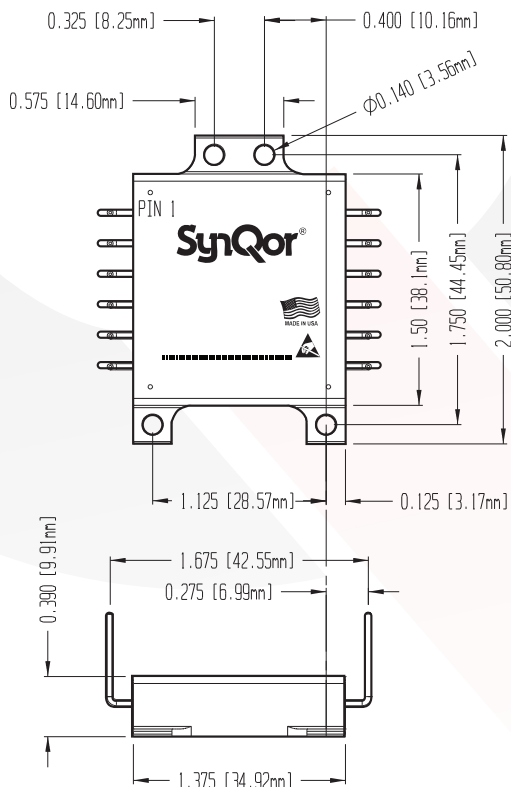

**Case W**

**NOTES**

- Case: Aluminum with gold over nickel plate finish for the C-, ES-, and HB-Grade products.
- Pins: Diameter: 0.040" (1.02mm)  
Material: Copper  
Finish: Gold over Nickel plate, followed by Sn/Pb dip
- All dimensions in inches (mm)
- Tolerances: a) x.xx +/-0.02 in. (x.x +/-0.5mm)  
b) x.xxx +/-0.010 in. (x.xx +/-0.25mm)
- Weight: 1.6 oz (45.4 g) typical
- Workmanship: Meets or exceeds IPC-A-610C Class III
- Pin 1 identification hole, not intended for mounting



**MQHE-28E-P**  
**Current: 10A**

**Technical Specification**

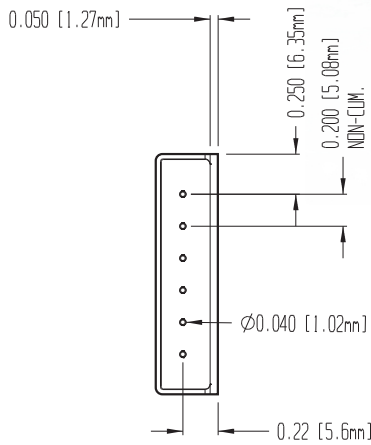
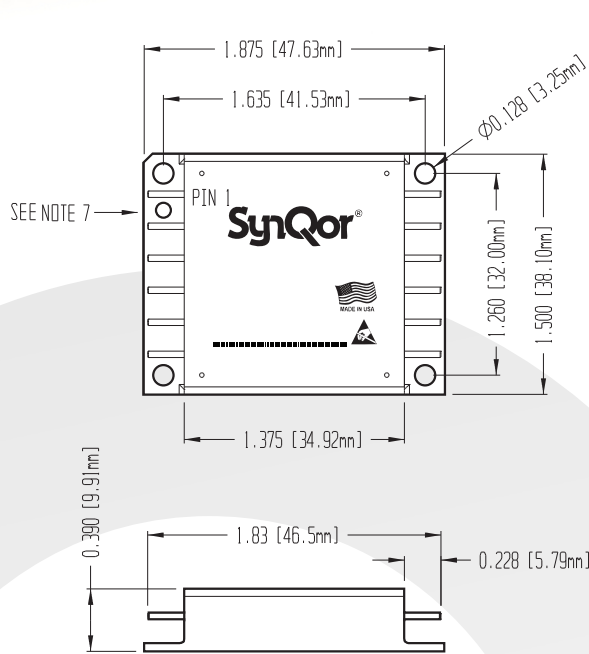

**Case X**

**PIN DESIGNATIONS**

Pin #	Function
1	Positive input
2	Positive input
3	Positive input
4	Input return
5	Input return
6	Input return
7	Output return
8	Output return
9	Output return
10	Positive output
11	Positive output
12	Positive output

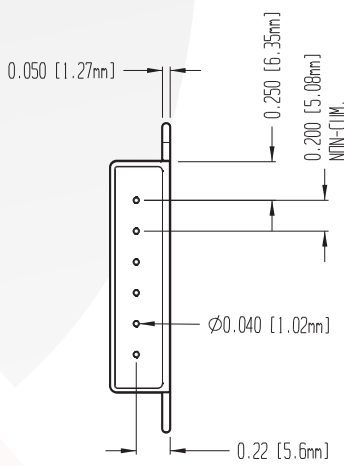
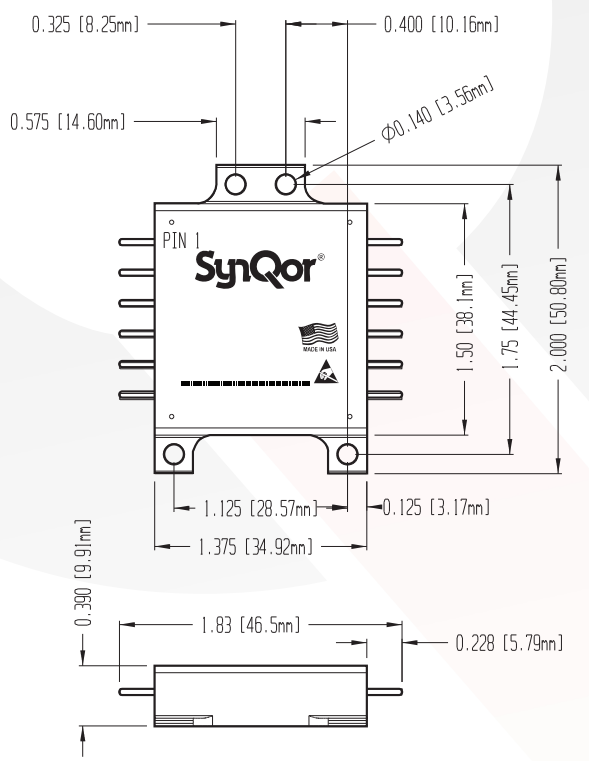

**Case Y**

**NOTES**

- Case: Aluminum with gold over nickel plate finish for the C-, ES-, and HB-Grade products.
- Pins: Diameter: 0.040" (1.02mm)  
 Material: Copper  
 Finish: Gold over Nickel plate, followed by Sn/Pb dip
- All dimensions in inches (mm)
- Tolerances: a) x.xx +/-0.02 in. (x.x +/-0.5mm)  
 b) x.xxx +/-0.010 in. (x.xx +/-0.25mm)
- Weight: 1.6 oz (45.4 g) typical
- Workmanship: Meets or exceeds IPC-A-610C Class III
- Pin 1 identification hole, not intended for mounting



**MQHE-28E-P**  
**Current: 10A**

**Technical Specification**

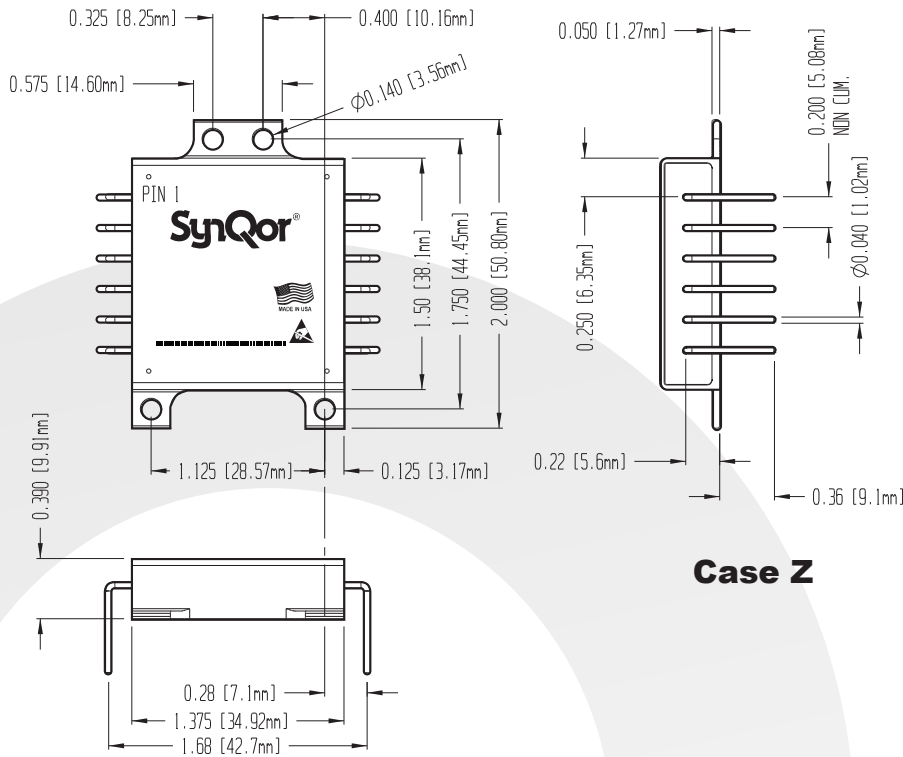

**PIN DESIGNATIONS**

Pin #	Function
1	Positive input
2	Positive input
3	Positive input
4	Input return
5	Input return
6	Input return
7	Output return
8	Output return
9	Output return
10	Positive output
11	Positive output
12	Positive output

**NOTES**

- Case: Aluminum with gold over nickel plate finish for the C-, ES-, and HB-Grade products.
- Pins: Diameter: 0.040" (1.02mm)  
Material: Copper  
Finish: Gold over Nickel plate, followed by Sn/Pb dip
- All dimensions in inches (mm)
- Tolerances: a) x.xx +/-0.02 in. (x.x +/-0.5mm)  
b) x.xxx +/-0.010 in. (x.xx +/-0.25mm)
- Weight: 1.6 oz (45.4 g) typical
- Workmanship: Meets or exceeds IPC-A-610C Class III
- Pin 1 identification hole, not intended for mounting



# Technical Specification

## MilQor Filter FAMILY MATRIX

The tables below show the array of MilQor filters available. When ordering SynQor converters, please ensure that you use the complete part number according to the table in the last page. Contact the factory for other requirements.

Product Family Designator	Continuous Input Voltage	Power (Amperage) Rating	Version (see table below)	Features Available (In Addition to Passive Filter Components)			
				Enable Pass-Through Circuitry	Transient Suppression Circuitry	Soft-Start Circuitry	Reverse Polarity Protection Circuitry
MQME-28	40V	320W (20A)	P				
MQME-28E	70V		T	•	•	•	•
			T6	•	•	•	•
MQHE-28	40V	160W (10A)	P				
MQHE-28E	70V						
MQHE-270	400V	160W (1A)	P				
MQME-270	400V	320W (2A)	P				
			R				•
MQME-270L	400V	200W (3A)	P				
			R				•





# Technical Specification

## PART NUMBERING SYSTEM

The part numbering system for SynQor's *MilQor* DC-DC converters follows the format shown in the table below.

Model Name	Input Voltage Range	Version	Package Outline/Pin Configuration	Screening Grade
MQME MQHE	28 28E	P T T6	U X Y W Z	C ES HB
	270 270L	P R		

Not all combinations make valid part numbers, please contact SynQor for availability. See the Product Summary web page for more options.

**Example: MQHE-28E-P-Y-ES**

## APPLICATION NOTES

A variety of application notes and technical white papers can be downloaded in pdf format from the SynQor website.

### Contact SynQor for further information and to order:

Phone: 978-849-0600 Toll Free: 888-567-9596 Fax: 978-849-0602

E-mail: [power@synqor.com](mailto:power@synqor.com) Web: [www.synqor.com](http://www.synqor.com)

Address: 155 Swanson Road, Boxborough, MA 01719 USA

### WARRANTY

SynQor offers a two (2) year limited warranty. Complete warranty information is listed on our website or is available upon request from SynQor.

### PATENTS

SynQor holds numerous U.S. patents, one or more of which apply to most of its power conversion products. Any that apply to the product(s) listed in this document are identified by markings on the product(s) or on internal components of the product(s) in accordance with U.S. patent laws. SynQor's patents include the following:

6,896,526 6,927,987 7,050,309 7,085,146

7,765,687 7,787,261 8,149,597 8,644,027